

# REIDAR

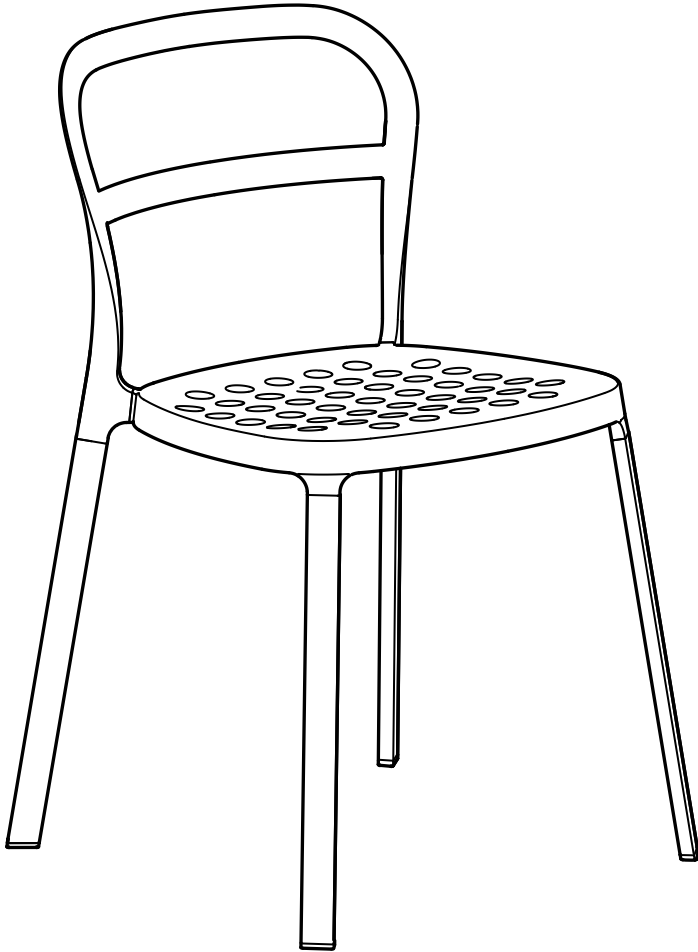

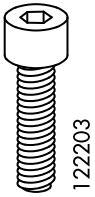

4x

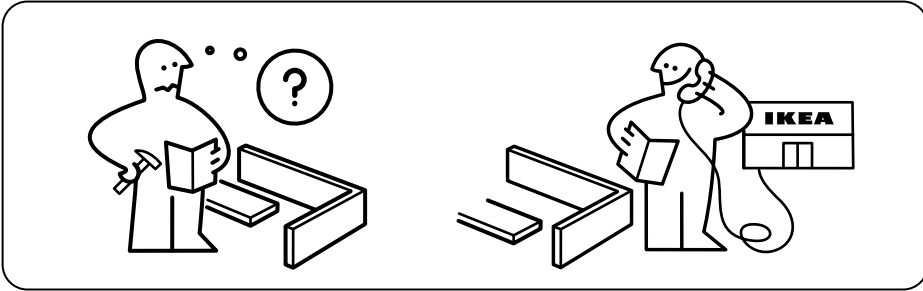
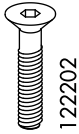

8x

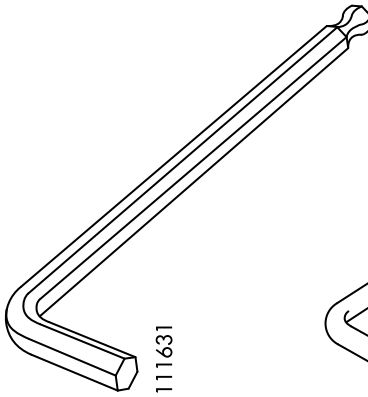

1x

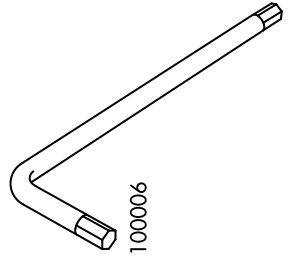

1x

1

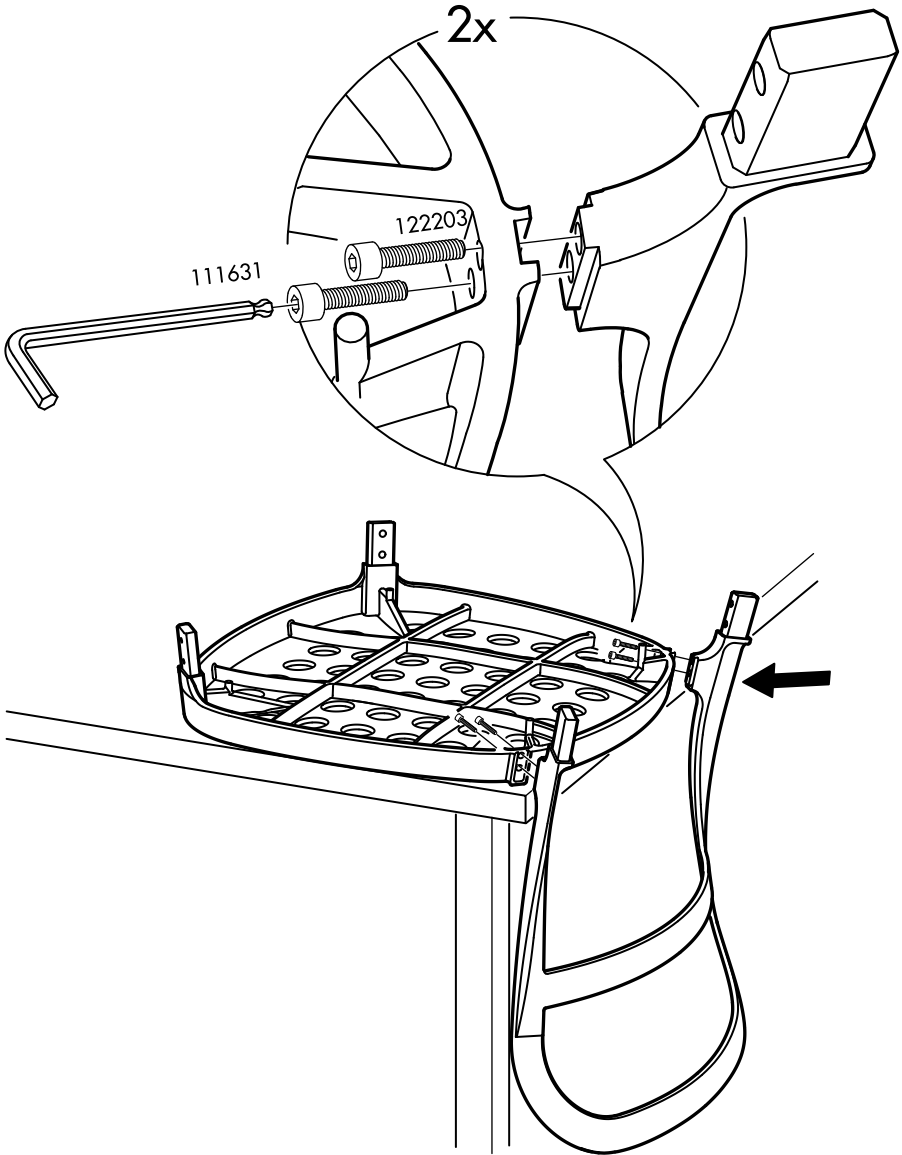

2

